

University Curriculum Development for Decentralized Wastewater Management

Controls

Module Text

Paul Trotta, P.E., Ph.D.
Justin Ramsey, P.E.
Chad Cooper

September 2004

NDWRCDP Disclaimer

This work was supported by the National Decentralized Water Resources Capacity Development Project (NDWRCDP) with funding provided by the U.S. Environmental Protection Agency through a Cooperative Agreement (EPA No. CR827881-01-0) with Washington University in St. Louis. These materials have not been reviewed by the U.S. Environmental Protection Agency. These materials have been reviewed by representatives of the NDWRCDP. The contents of these materials do not necessarily reflect the views and policies of the NDWRCDP, Washington University, or the U.S. Environmental Protection Agency, nor does the mention of trade names or commercial products constitute their endorsement or recommendation for use.

CIDWT/University Disclaimer

These materials are the collective effort of individuals from academic, regulatory, and private sectors of the onsite/decentralized wastewater industry. These materials have been peer-reviewed and represent the current state of knowledge/science in this field. They were developed through a series of writing and review meetings with the goal of formulating a consensus on the materials presented. These materials do not necessarily reflect the views and policies of University of Arkansas, and/or the Consortium of Institutes for Decentralized Wastewater Treatment (CIDWT). The mention of trade names or commercial products does not constitute an endorsement or recommendation for use from these individuals or entities, nor does it constitute criticism for similar ones not mentioned.

Citation of Materials

The educational materials included in this module should be cited as follows:

Trotta, P.D., and J.O. Ramsey. 2005. Controls Text. *in* (M.A. Gross and N.E. Deal, eds.) University Curriculum Development for Decentralized Wastewater Management. National Decentralized Water Resources Capacity Development Project. University of Arkansas, Fayetteville, AR.

Controls

I. Overview

A. Scope

The systems designed and built in the onsite and decentralized wastewater field have had their capabilities greatly enhanced in the past few years by the rapid development of the controls available to the designer, installer, O&M professional, and regulator.

Historically, onsite systems were passively controlled through the careful design of the hydraulic elements that were linked together to form a system powered only by gravity. Mechanically operating controls if present at all in early systems consisted of weirs, orifices, sluice gates, and assorted valves. Most of these mechanically operating controls were passive and not changed except in the most extreme cases of malfunction.

B. Introduction

The use of active and reactive control for system adjustment or operation is relatively new in decentralized or onsite systems. Just a few years ago the basic control element for what was then considered an elaborate onsite systems was a simple float switch often directly wired in series with the pump and electrical supply. Controlling the length of the wire connecting the float to a fixed point was the only available adjustment to the system. Now programmable timers are becoming common. Digital interfaces with hand held data collectors or with phone line based communications links via modems (with and without the use of the internet and World Wide Web) are gaining attention especially in areas where there is active regulatory oversight or service provider networks. Improvements to active (but not electrically powered) mechanical controls have also enhanced design and operational options and are well suited for areas where electronic and even electrical controls are impossible (no electricity) or impractical (no maintenance capability).



Figure 1: Controls and Control Panels come with a variety of capabilities. (SJE-Rhombus)

Figure 1 shows a manufacturers display of a variety of control panels available in the onsite industry today. These panels range from simple on-off-alarm panels using only float settings to determine the characteristics of the systems operation to more elaborate panels which have programmable timers, elapsed time meters, event counters, data acquisition modules, programmer interfaces and even telemetry interfaces. The use of this modern control equipment allows far more operational flexibility and can increase overall system performance and efficiency in communities where electrical power is accessible either on the grid or off the grid and/or where telephone lines are available.

Figure 2 shows the interior of a panel that has several of the capabilities identified above. The technologies illustrated in this panel are common in a wide range of industrial applications. The most advanced features of this panel are the elapsed time counter and event counter (near top of enclosure) and a programmable timer (analog) located in the center of the enclosure. The other components shown are such common elements as circuit breakers, master control switch, pump controllers (relays) and bus bars for making connections.

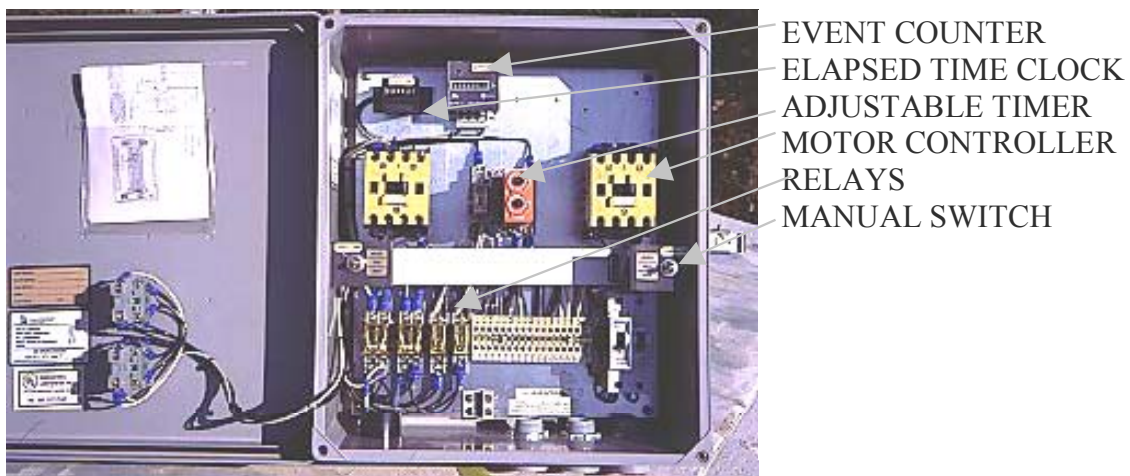

Figure 2: Controls and Control Panels come with a variety of capabilities. (*Gross-Control Panels-9-11*)

Figure 3 shows the interior of a slightly newer technology panel that has several of the capabilities identified above plus other capabilities enabled to a large extent by the rapid advancements in electronics and computer technology. The technologies illustrated in this panel are becoming more common in the onsite industry. The most advanced features of this panel are the digital electronic circuit board that switches transistors, which switches low voltage relays that in turn switch the motor control relays. The digital electronic circuit board interfaces with a Personal Digital Assistant (PDA) that is used to download data and upload control logic and settings

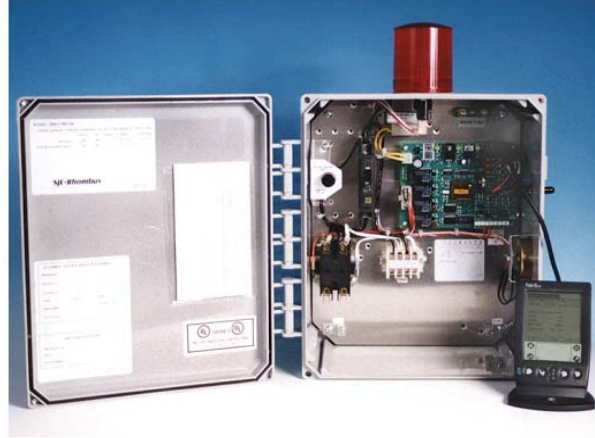

Figure 3: Elaborate Digital Control Panel with Palm Pilot Data Acquisition (*SJE Rhombus*)

A control feature for an onsite wastewater system can be as simple as a valve, weir or orifice. The simplest electrical control is generally a float switch turning on or off a pump or blower. An alarm can be a simple float switch connected to a visual (light) or audible (buzzer or bell). The logging or recording of data can be simply achieved by elapsed time clocks or event counters. All of these functions can be enhanced to achieve additional levels of sophistication in the control, communication of problems, and recordation of data. Modern electronics make a large variety of capabilities possible. In spite of all the technical sophistication available the designer needs to keep the system as simple as possible to keep the reliability high and the costs down while at the same time provide the control level needed to insure operating performance, compliance with regulations, safeguards for public and environmental health and facilitate the management of decentralized systems.

II. Hydraulic and Mechanical Controls in Onsite Wastewater Systems

Some control of the wastewater system's operation is built in and passive and permanent while some of the control is automated and easily adjusted. Traditional onsite systems tended to be passively controlled through the use of the hydraulic structures that were part of the system. Newer mechanized systems have more active controls that may be strictly mechanical or electromechanical.

A. Fixed Control Built in Initial Design

Many features of an onsite wastewater system are permanently controlled through the initial design. Controls that are designed, constructed and set for the life of the system during installation can be referred to here as *Fixed Controls*. The most obvious example

of a Fixed Control is the initial design of gravity flow hydraulic elements within an onsite system. For example, a septic tank is “controlled” through its design. The concrete weirs, baffles and orifices in a septic tank are not adjustable but effect control of the treatment within the septic tank. The elevations and locations of the baffles between compartments establishes the detention time in each section of the tank as well as controlling the discharge of scum and sludge.

Similarly, the slope of the gravity flow influent and effluent lines controls the velocity and depth of flow in those lines. The arrangement of the manifold, laterals and orifices in a dispersal field also control the distribution of the effluent.

Figure 4 shows a simple septic tank. Control of the operation of this treatment device is designed in and consists of:

- The volume and dimensions of the tank
- The elevation difference between the inlet and outlet features
- The use (or lack of use) of internal baffles, orifices and weirs
- The hydraulic control of the inlet achieved by the energy dissipater anti-siphon pipe configuration.
- The screened outlet device with predetermined screen hole size and area.

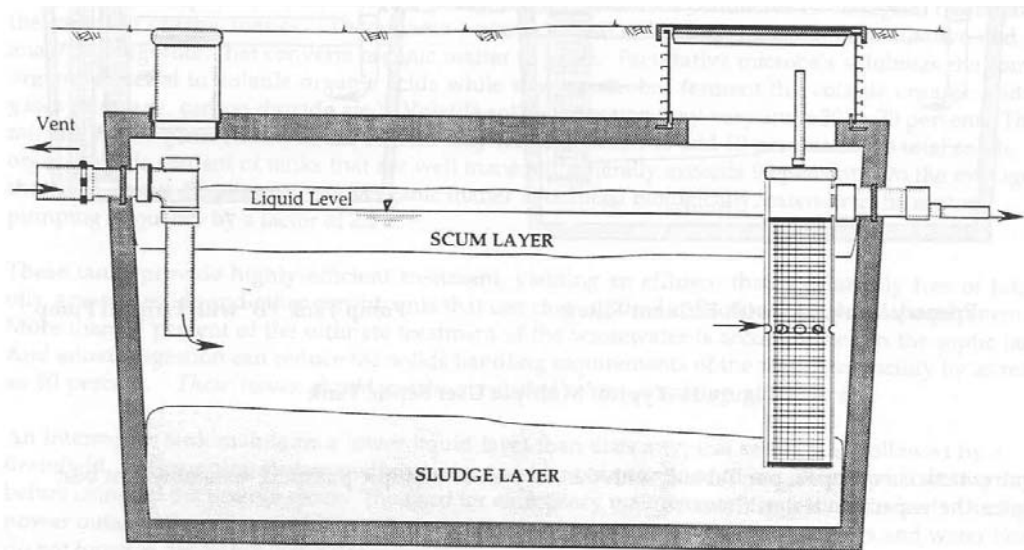

Figure 4: Control Built Into a Septic Tank (Orenco)

Carefully designing the relative elevations of the various components of a wastewater system controls its operation to a certain extent. Whether operating with gravity flow or pressure dosed, the slopes, hydraulic grade lines and conveyance characteristics of the hydraulic elements control flows and discharges. Many of these are established during the initial design and are often not subject to change after installation. Passive controls have the advantage of being simple, almost fool proof and generally very reliable. Figure 5 illustrates the use of the hydraulic grade line to show how the passive hydraulic elements in the system (the pipes) work with the mechanized elements (the pump) to control the discharge from the STEP (septic tank effluent pumping) system.

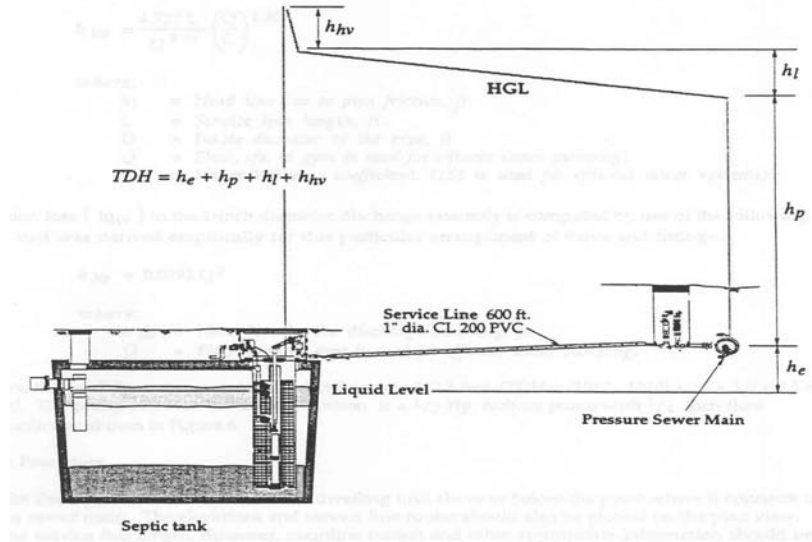

Figure 5; Hydraulic Grade Line Achieves Fixed Control

B. Operational Controls

There are a variety of passive (not automatic but with limited adjustment) and fully adjustable operable controls that are included in the design and used in the operation of an onsite system that are amenable to manipulation after the system is built. Adjustable operational controls include hydraulic, mechanical and electro-mechanical and often have one or more user-determined settings that can be changed with only minor interruption of the system.

Onsite systems are mostly hydraulic in nature and most of the control of these systems is intended to influence aspects of the flow of the influent, partially treated, and treated effluents. Hydraulic control determines:

- The normal passage of partially treated effluent between treatment stages such as sedimentation, aeration, nutrient reduction, clarification and disinfection.

- Overload, surcharge or high flow treatment options
- The recirculation of partially treated effluent within or between one or more treatment stages.
- The controlled discharge of effluent into soil dispersal systems.

There are onsite technologies that depend upon control of non-hydraulic aspects of the treatment process in addition to the flow of the water. Such non-hydraulic control considerations include control of:

- Air supply and venting for aerobic treatment units (ATU's)
- Chemical flows if needed for treatment (disinfection)
- Ozone generators or ultraviolet lights.

This module will focus primarily upon hydraulic control of onsite systems. Operational hydraulic controls will be sorted into two categories:

- Passive Hydraulic Controls
- Active (automatic) Hydraulic Controls

1. *Passive Hydraulic Controls*

Controls that are adjustable at the time of installation or later during system maintenance but are not readily used as control on a daily or weekly basis can be referred to as Passive Controls. Generally during normal operation of the system no parts of these control are expected to move although simple tipping bucket devices which have a simple flip-flop oscillation driven by simply the weight of effluent may be considered passive as well.

An example of a simple passive hydraulic control would be the common “Bull Run” valve shown in Figure 6 that will divert gravity flow effluent from one dispersal field to another. It has a moving part that is manually operated as needed.

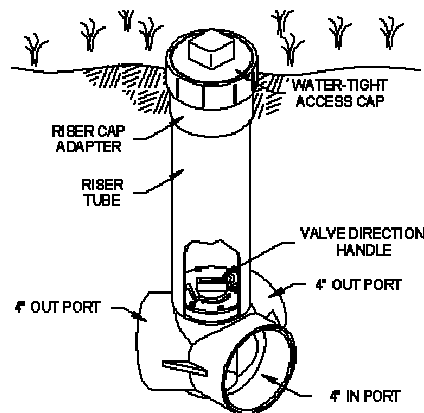

Figure 6: Bull Run Valve (American Manufacturing)

The American Manufacturing DIAL-A-FLOW™ shown in Figure 7 is a device for equally distributing flow out of distribution boxes. With the eccentrically located opening the installer can rotate the DIAL-A-FLOW™ within the stationary outer ring to balance all discharge ports for equal flow. This enables:

- Balancing of the several portions of a dispersal system which would otherwise be unequally loaded due to a unlevelled splitter box
- Control or limit the discharge to a disposal trench which is failing,
- Utilization of emergency capacity in back up disposal areas or trenches



Figure 7: Adjustable Weir for Controlling Open Channel Discharges (American Manufacturing Catalogue)

The “Equalizer” by Polylok shown in Figure 8 is another adjustable weir device that enables adjustments of the discharge to each disposal field connected to a distribution (“D”) box. It is claimed to automatically compensate for a limited amount of D-box movement and enables a differential loading of septic trenches that may have unequal lengths or infiltration capability.

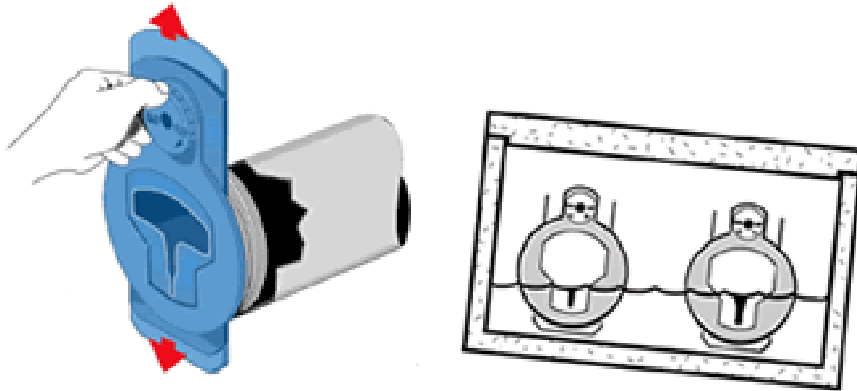

Figure 8: Equalizer (Polylok)

The control adjustments available through either of these devices can be made during construction and again during system inspection. They are considered operational and passive since it is unlikely that frequent adjustments would be made to this control device during most of the system life.

2. Automatic Mechanical Controls

Controls that operate automatically during the normal functioning of the onsite systems may be referred to as Automatic Mechanical Controls. Simple automatic mechanical controls include:

- Mechanical float valves
- Ball float valves
- Sequencing valves
- Self priming siphon dosing valves
- Tipping dosing plates

Mechanical valves like the valves found in everyday toilets use the buoyancy or increasing pressure of the rising liquid level to provide the force needed to actuate the mechanical valve. Such mechanical devices require no electricity or external pneumatic power for their operation. Since they are not capable of switching electrical power their use is limited to controlling water levels. Figure 9 shows the inside of a common flush toilet and illustrates the use of a float to control the flow of water out of the toilet during a flush (Toilet Tank Ball) and into the toilet after a flush (Toilet Tank Ball).

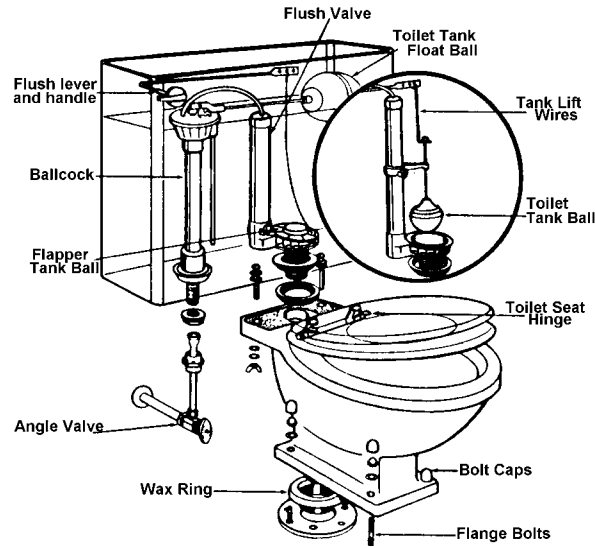

Figure 9: Inside of a Toilet Showing Mechanical Float Valves

Hydraulic controls for onsite systems also include the use of a floating ball to control the diversion of water out of a re-circulating tank when additional influent enters the tank. With rising water levels a ball seats in a complementary designed socket thereby prohibiting all or part of the pumped effluent from re-circulating back into the tank for additional processing. Figure 10 illustrates a complete ball float valve in its housing. The ball is located in the lower cage. The pressurized or gravity flow effluent blocked from reentering the tank discharges out a permanently opened bypass line to the dispersal field or pump vault. Splitter Valves redirect 100% of the incoming flow to the re-circulation tank during periods in which the ball is not seated and 80% or less when the ball is seated. They can be field-adjusted for splits ranging from “no split” (as with re-circulating ball valves) to a 4:1 split. The desired re-circulation ratio will be achieved even during peak flows.



Figure 10: Re-circulating Ball Valve (OSI)

The hydraulically operated automatic sequencing valve pictured below in Figure 11 automatically switches the discharge from the currently opened port to the next thus enabling the cycling of discharge to each of several dispersal features. One advantage of this hydraulic control is the ability to reduce the overall pump size by reducing the total system flow rates. This is accomplished by discharging to only one dispersal feature at a time without the need for electro-mechanical actuators (solenoid valves) and an elaborate control panel. However, there is little ability (without disassembly) to turn off an outlet and there is no way to change the discharge flow rate to each outlet without additional external valves, orifice plates or timers in the pump control panel.



Figure 11: Mechanical/Hydraulic Sequencing Valve (OSI)

Automatic siphons are useful control devices for dosing a dispersal field if the hydraulic grade line supports the required change in elevation between the siphon and the down gradient dispersal field. Most mechanical controls have moving parts although the siphon-dosing valve does not. It could, therefore, be classified as a passive device although its operation is active. Figure 12 illustrates an automatic siphon that makes use of the rising tank water in a sealed larger outer cylinder to develop sufficient pressure to prime the siphon. The siphon has no moving parts but allows control of the discharge by careful planning of the siphon start and end water levels in conjunction with the discharge tank's horizontal dimensions. The siphon pictured is shown in a partially cut away chamber.



Figure 12: Self-Priming Siphon Valve (OSI)

Figure 13 shows a tipping dosing plate that achieves a controlled dosing of the peat media in an Ecoflow peat bio-filter. The laterally divided triangular dosing container fills on one side of the divider, spills and as it tips it places the other side of the divider under the flow which in turn fills and tips repeating the dosing cycle.

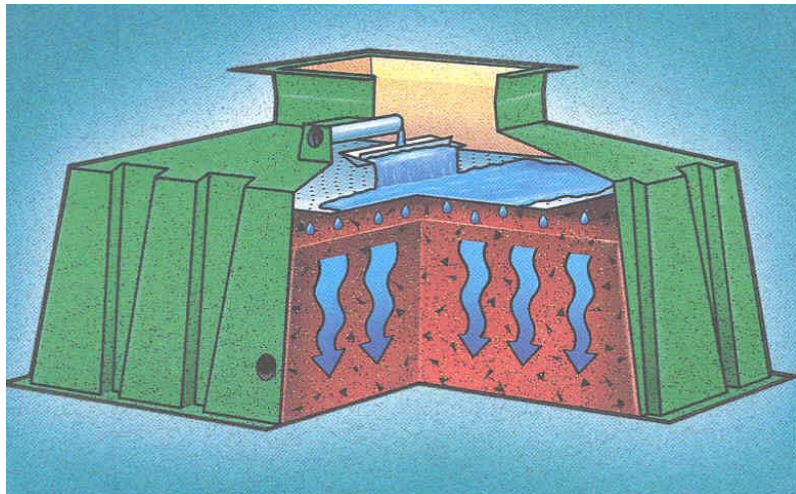

Figure 4: Tipping Dosing Plate (Ecoflow)

Figure illustrates the use of the tipping bucket to control discharges to a series of trench supply lines.

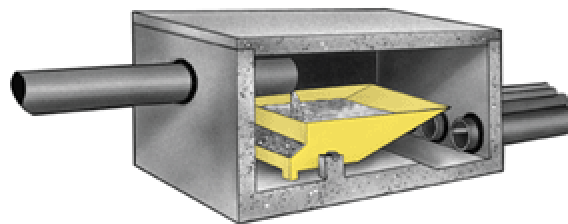

Figure 14: Tipping Bucket Distribution System

III. Electro-Mechanical Controls in Onsite Systems

Electro-Mechanical controls generally include at least three components; a sensing feature, a switching feature and a controlled device. These features work together to provide some operational capability needed by the system.

The sensing features for hydraulic control includes:

- Float switches of all sorts,
- Pressure transducers,
- Conductivity probes, and
- Devices that bounce a signal (sound wave, microwave, light etc) off a liquid surface.

The sensing feature could also be for monitoring process features other than hydraulic conditions. A sensing feature used for monitoring non-hydraulic conditions include:

- Temperature probes
- pH probes
- Dissolved Oxygen probes
- Changes in density (scum, effluent & sludge)

A. On Site Controls with Electrical Float Switches

1. Float Switch Features

The electrical float switch can be one of the most critical elements in the design of mechanized onsite systems. The switching feature can be as simple as an electrical contact inside the float, or can involve either mechanical or electronic relays in addition to the electrical switch in the float. The float switch with or without additional circuitry is used to control the electricity to a process control device. The process control device can be a pump, solenoid valve, air blower, chemical dosing device, or an alarm signal or light.

Float switches have several main components:

- The connecting electrical line or tether
- The float
- The internal position sensitive switch
- A weight (which is optional if the float is anchored to a pole)

Figure 54 illustrates the features of a simple float. The float switch illustrated has a weight to allow it to be placed in a tank without the need to be attached to a vertical support.

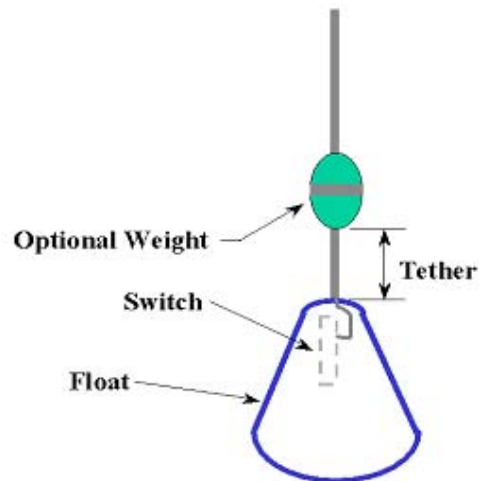

Figure 54: Components of a Simple Float Switch

Float switches fall into three main categories:

- Narrow angle pilot float switches
- Wide angle pilot duty float switches
- Wide –angle motor control switches

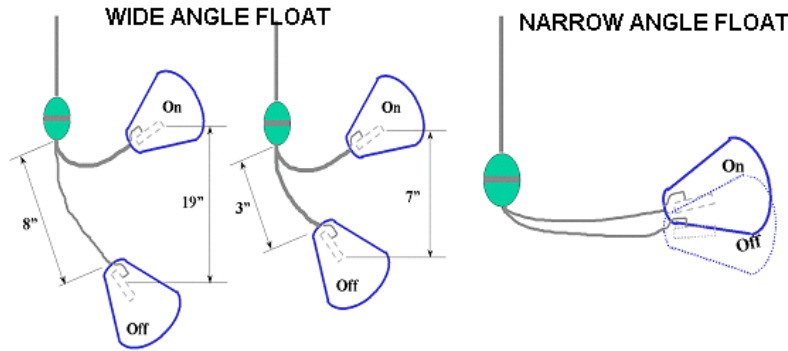

Figure 15: Wide Angle and Narrow Angle Float Switches

Figure 15 illustrates the difference between a narrow angle float switch and a wide-angle float switch. The tether length controls the operational range of the wide-angle switch. The narrow angle switch can react to small changes in the water level. The angle of operation dictates the range of water levels the float can control.

If the switch has a current and voltage rating sufficient to carry the start up and running current for the device being controlled (e.g., a pump motor) the switch is considered “Motor Duty” if not than the switch is considered “Pilot Duty” and is suitable for carrying only the current and voltage needed to trigger a relay switch mounted in a control panel outside the tank.

Pictured in **Error! Reference source not found.** and 17 are the inner workings of two typical kinds of tethered floats. Most common are the mercury switch and the mechanical ball type. Both depend upon gravity to pull a weight down thereby providing the mechanical effort needed to close a circuit. In the case of the mercury switch, mercury that is both a conducting metal and a liquid is contained in a glass enclosure that is attached to the float and rotates with the float. Gravity causes the mercury to flow to the low point in the enclosure where it floods around the electrical contacts and closes the circuit. In the case of the mechanical ball switch, gravity is again used to cause a ball to roll from one end of its enclosure to the other where it impacts upon a mechanism that closes an electrical switch.

Each type of float has applications to which it may be better suited although manufacturing refinements always tend to make each type more competitive in the other’s traditional domain. The mercury switch can result in motor chattering if the mercury bobs back and forth with small perturbations of the water surface. This, however, can be overcome by having the glass enclosure somewhat curved so that the mercury has to make it over a “hill” before it can flow from one end to the other. Mechanical switches can have the same problem if there is no similar design feature to stop the ball from rolling back and forth with small water surface perturbations. Friction has helped simple ball switches to overcome this issue since friction will result in the need for a greater rotation before the ball will roll.

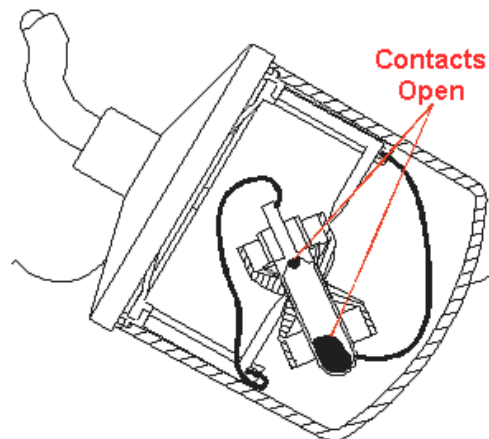

Figure 16: Mercury Float Switch (SJE Rhombus)

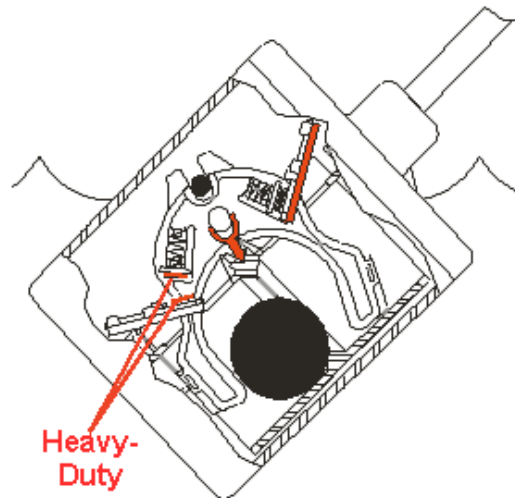

Figure 17: Mechanical Float Switch (SJE Rhombus)

In either case care must be taken by the designer to ascertain the angle required to actuate the switch to open or to close. If, however, the float is to be used to directly control the electricity, greater care must be taken to insure that small changes in the water surface do not cause unnecessarily large number of pump on and off cycles. Excessive pump cycling can lead to premature wear and failure of the motor. To eliminate this possibility switches that have a wider angle between on and off can be used.

Simple tethered floats of any sort require knowing the operating range or angle for the float switch. Careful design can lead to simple reliable and inexpensive systems that take advantage of the inherent operating characteristics of the float switches rather than trying to overcome the operating characteristics by adding unnecessary complexity to the system.

As in all cases the designer should endeavor to keep the system as system and reliable as possible. If a simple tethered direct control switch will suffice there is no need to design in an elaborate control panel with relays.

A simple tethered float of any sort requires knowing the operating range or angle for the float switch. Careful design can lead to simple reliable and inexpensive systems that take advantage of the inherent operating characteristics of the float switches rather than trying to overcome the operating characteristics by adding unnecessary complexity to the system.

2. Demand Dosing With Floats

a. Single Float System

The most common use of electrical floats is to achieve control over the discharge from a holding tank to either the next step in the treatment or to the disposal field. In this arrangement the dose volume is controlled by a single “Motor Duty” float. The float angle and tether length as well as the volume of the tank between the limits of the float’s swing determine the dose volume. Figure 18 illustrates a simple motor duty float controlling a pump. Any adjustment to the dose volume must be made either by the initial decision on the tank’s geometry or by adjusting the tether length.

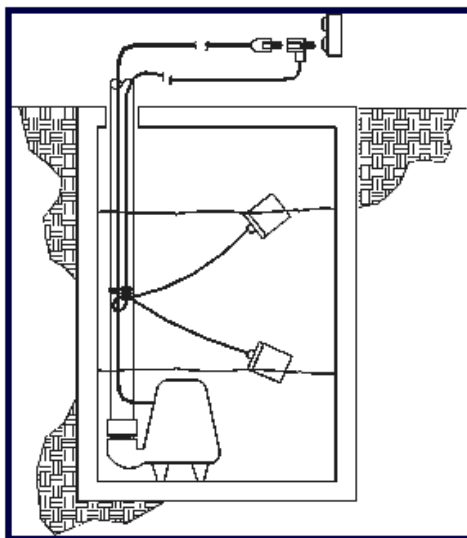

Figure 18: Single Float, Demand Dose Pump Control (SJ Rhombus)

The float switch mounted in the tank rotates as a result of a tether that ties it to a stationary point or weight in the tank. As the switch rotates past a critical point the switches mechanism turns on the electricity and in turn the pump. The pump discharges effluent from the tank and the water level drops. As the switch floats down and rotates back to its original position a second critical point is reached opening the circuit turning off the electricity and stopping the pump. The float switch can handle the complete current needed to energize the pump so no relays or control panels are needed. This cycle repeats as influent or treated effluent enters the tank. Such simple control systems may be obsolete for application in communities where regulations require on-off-automatic master switch and/or high water alarms.

The system described above allows control of the dose volume but does not allow control of the dose timing. While simple and relatively fool proof such systems provide no capability for collecting data or scheduling the pumps operation through time. While being active control in the sense that there are electromechanical parts that actively control the pump it is totally reactive and operates not on a predetermined schedule but rather when cumulative random flows dictate that the pump should come on. In the above design the discharge volume is completely determined by the tether anchor position, the tether length and the design of the float switch. This type of control is referred to as “demand dosing”.

Tethered floats can be connected to weights and hung into a tank or attached to a vertical support. Each arrangement affords the designer different opportunities to create an efficient and reliable design. Figure 19 illustrates these options.

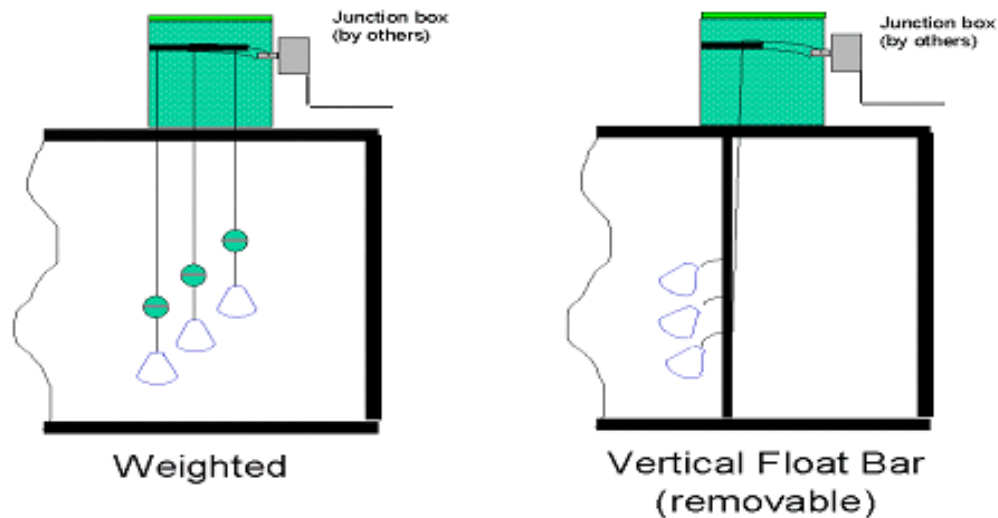

Figure 19: Weighted vs. Attached Floats (American Manufacturing)

Not all float systems use tethers to control the operating range of the system. Simple float switches are available in which the float travels vertically along a rigid rod. The operating range is limited by the length of the rod and the mechanical connection to the switch inside the watertight housing. The float coming in contact with the switch assembly activates the switch; so theoretically, the rod can be any length. Design reliability may limit the length of such floats.

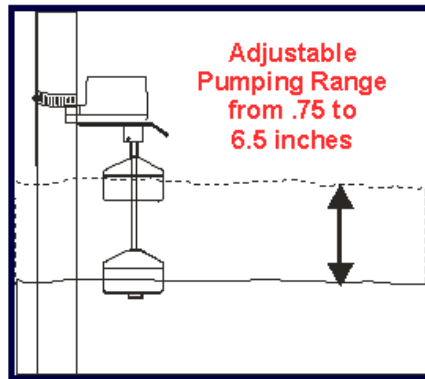

Figure 20: Achieving Control & Design Objectives with One Vertical (no tether) Float (SJE Rhombus)

Demand dosing results in a dosing schedule that is dictated entirely by the incoming flow and the set points of the floats. Figure 21 below shows a hypothetical graph of incoming flows and pumped discharges from a demand dose system. Note that the entire dose from the Pump On position to the Pump Off position is discharged to the dispersal field at one time and that dose timing reflects not the limitations of the downstream device or disposal field but rather the supply of water coming into the tank.

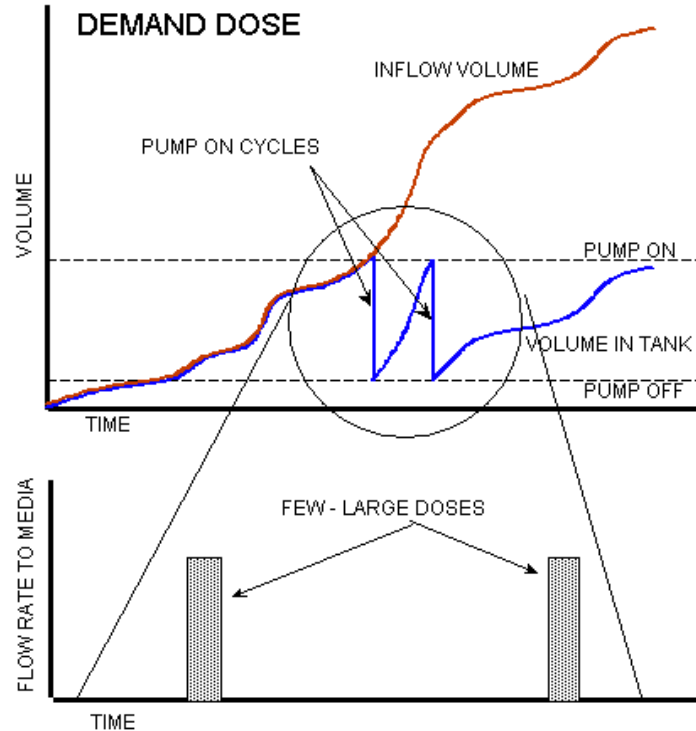

Figure 21: Demand Dosing

A single float system can be used in conjunction with a control panel that incorporates a timer so that between the limits of the float's operating range the electricity flowing to the pump can be cycled on and off to achieve an interrupted demand dosing. This overcomes some of the potential problems of simple demand dosing but will still concentrate the dosing within the high demand period. Careful design incorporating a larger tank can allow such a simple system to equalize the doses over any planning interval, typically one day.

It is generally acknowledged today that controlling the dosing and resting of media used for biologic treatment (whether in the treatment device or in the dispersal trench) enhances the continued treatment of effluent. The media may be man made or man placed media within an engineered structure. A sand filter or a re-circulating aerobic treatment unit is man made device that uses natural materials (sand) or synthetic materials to provide surfaces for the bacteria. The natural soils on a site can be used as both a treatment step as well as a dispersal device. The optimum use of these media is achieved through controlled dosing and resting of the media with predetermined dose quantities.

Controlled dosing and resting of media with predetermined dose quantities can be achieved through the use of one or more floats in conjunction with a programmable timer. Figure 22 below illustrates the inflow and controlled outflow from a dosing tank that makes use of both float switches as well as a programmable timer.

The float switches activate the programmable timer that interrupts the dose after a predetermined quantity of effluent is dosed to the media. It also provides a rest period for the media between doses.

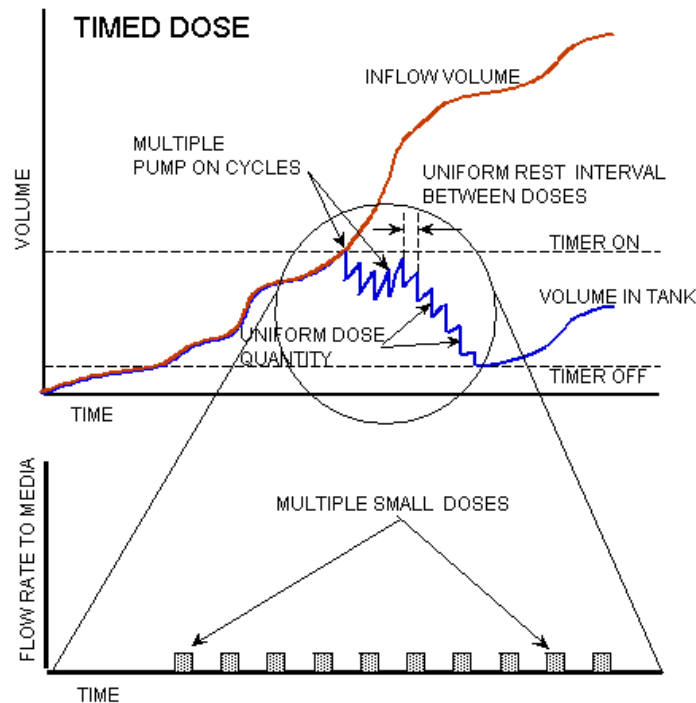

Figure 22: Timed Dose

b. Two-Float System

In many applications the use of a single float that directly controls the electric current becomes unworkable and a two-float system becomes necessary. There are several reasons why a two-float system may be necessary.

- The tank geometry makes it impossible to adjust a tether to achieve the desired dose. Either the desired change in tank elevation is too small for the limitations of the float or too large to use a tether without the risk of excessively long tethers which could tangle and foul with other equipment.
- The hydraulic limitation of the feature to which the pump is discharging (additional treatment or dispersal feature) requires doses spaced evenly through time.
- A high water alarm or warning signal is necessary.

Figure 23 illustrates a simple two-float system. The top float will close the circuit with rising water while the bottom float will open the circuit with falling water. These two floats must be wired in series and require no control panel or relays to achieve a relatively wide range of control. Such a system is still a Demand system with no capability for timing the doses or sounding a high water alarm.

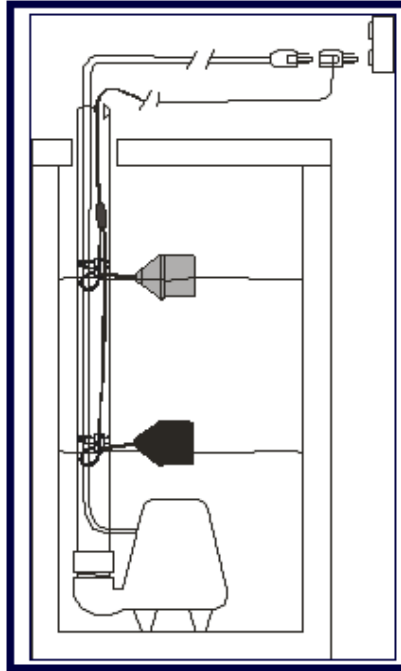

Figure 23: Achieving Control & Design Objectives with Two Floats (SJE Rhombus)

c. Three- & Four- Float Systems

With more floats more functionality can be achieved. Additional floats enable the addition of:

- High water alarms
- Second (Lag) pump operation
- Timer bypass for continuous pump on operation

Figure 24 below illustrates the use of three floats to control a duplex pumping system in which the second pump will come on after an alarm sounds. There are many configurations of floats and float functions that the designer can incorporate into a modern onsite system. The understanding of the capabilities of the various floats available in conjunction with the various control panels available gives the designer a wide range of options.

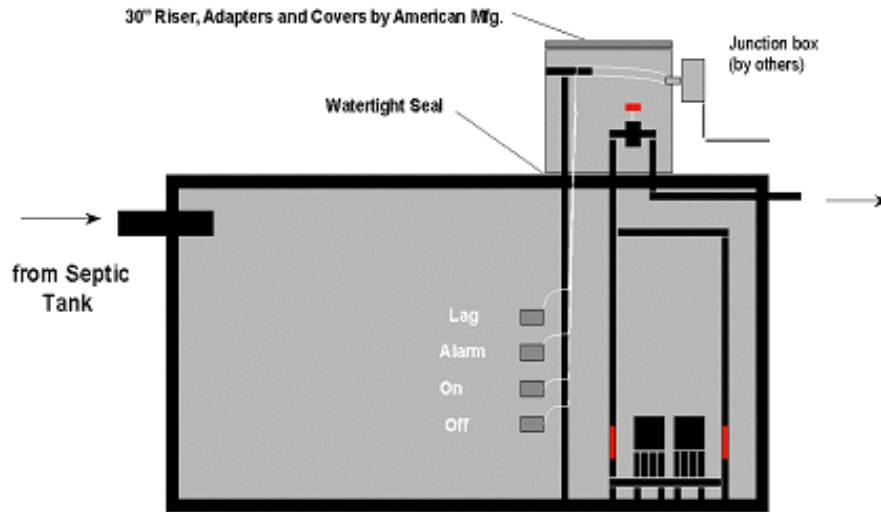

Figure 24: A Four-Float System Controlling Two Pumps and Alarm (Am. Manufacturing)

B. Control Systems for Onsite Wastewater

Many of the devices referred to as “controls” do in fact control some aspect of the wastewater system directly. Other “controls” are actually part of monitoring systems that may influence controls, sound alerts or may just record data for future analysis. Control systems can therefore be divided into four categories:

- Controls which operate the system routinely and automatically
- Controls which alert local operators to immediate and emergency conditions
- Controls which collect data for long term management decisions
- Controls which interface with larger automated management systems

1. Automatic Operational Controls

A wide range of control panels are available today with both standard and custom features. The panels affect the necessary system control by turning on and off equipment, opening and closing valves and starting and stopping air blowers. These automatic operational controls have been described above in the section on float switches and electro-mechanical controls and are summarized as:

- Pump controlled with attached float (demand dosing)
- Pump relays for simple on off function (demand dosing without timers)
- Pump relays and timers to allow timed interval dosing.
- Above plus a timer override function to change the dose on and off timing
- Above plus the control of a second pump (duplex system) for backup and/or discharge of high flows

In addition, advanced wastewater treatment devices use automatic operational controls to:

- Control of process cycles in sequential batch reactors
- Control recycling of partially treated effluent in re-circulating filters
- Control aerobic processes (aeration and/or agitation)
- Control of de-nitrification processes through careful oxygen control
- Monitor water pressure in disposal system
- Control recycling and back flushing of drip systems
- Control (limit) discharges to disposal fields

2. Local Operator Control Aids

In addition control panels are often used to facilitate local supervisor control functions by alerting local operators to system status and malfunctions and by collecting data used in long range operational decisions. The most fundamental local alert function is the high water alarm that is often part of the simplest mechanized system. Figure 25 shows the basic equipment needed for stand-alone high water alarm system. Such a system will typically have an audible and visible alarm to alert the operator (and/or system owner) to a high water condition in a tank.



Figure 25: High Water Alarm (American Manufacturing)

However, more and more functionality has been provided in control panels for the benefit of the system operator. Increasing in complexity, panels include the following functions:

- Recording total elapsed time for a motor or blower.
- Recording the total on and off events for a motor or blower.
- Recording the total number of alarm situations noted by the system
- Recording high or low current conditions for motors
- Recording high or low temperatures
- Recording high water conditions in disposal trenches
- Recording and/or alarming low water conditions.
- Recording and/or alarming clogged effluent filters

One of the most important indicators of the systems status is the overall quantity of effluent treated over a defined time period. The total discharge and average discharge flow rate between measurements can reveal:

- Excessive homeowner use of the system due to changes in the family size or habits.
- Leaking fixtures in the home contributing to system overload.
- Infiltration into the tanks from ambient ground water, surface runoff or snow melt.

Information relating to the total discharge can be obtained from direct reading standard water meters installed on the discharge side of an effluent pump. Such meters are similar to those that are used with municipal water supply. The residential water meter is, of course, in most cases a pre-existing wastewater meter as well as long as there is no significant use of water for purposes which do not contribute to wastewater generation such as washing cars, watering lawns, landscaping or gardening. Such meters are useful only if someone takes the time to record the total discharge at recorded points in time like what is done by a municipal water company.

Indirect means of determining the total discharge from residential onsite systems have become popular due in part to the lower cost, and maintenance free convenience of the simple electrical components required. Among the types of devices that can provide indirect information about the total system use are elapsed time meters and/or event counters connected in the pump circuit.



Figure 6: Elapsed Time Meter

The elapsed time meter pictured above in Figure 26 reveals the total amount of time that the pump has been running. If the pumps discharge flow rate is known it can be multiplied by the elapsed time to determine the total amount of effluent discharged since the last measurement. By itself it is a useful measure of the pumps total number of hours that can give an indication of the pumps remaining life or need for scheduled service. The discharge flow rate, however, can change considerably through the life of the system due to:

- Wear or damage to the pump's impeller.
- Degraded performance of the electrical motor.
- Change in friction in the pipes.
- Clogging of discharge orifices.
- Increased discharge head resulting from flooded trenches.

An event counter as shown in Figure 27 also provides useful information about system performance. They can be used by themselves or in combination with elapsed time meters.

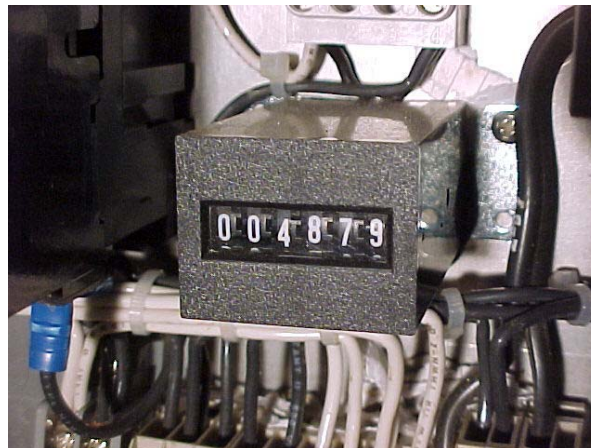

Figure 27: Event Counter

Event counters when added to the pump's circuit will increment each time the pump is turned on. If the tank dimensions and water elevations at the points that activate the float switches are known, the total discharge can be obtained by simply multiplying the number of events by the volume of the tank between the float activation points.

Estimating total discharge between times when the number of events has been recorded is also subject to error. Error can result from:

- Changes in the float switches operation due to wear or interference by debris in the tank.
- Excessive cycling of the pump due to a “chattering” single float that is bobbing on the water surface.
- Water flowing into the pump chamber during a pumping cycle
- Planned (designed) drain back of discharge lines for freeze protection.

Working together the elapsed time meter and event counter can provide the system operator with valuable insights into the system's overall performance. By comparing the discharge estimated by the number of events from the discharge estimated by the cumulative operating time of the pump preliminary diagnosis of a system's problem may be derived.

3. Automated Septic Tank Monitoring

With the increase of complexity of onsite systems there is an increased opportunity for things to go wrong and correspondingly there are increased opportunities for corrective control and system diagnostics. The simplest float operated control systems have three conditions for the pressure discharge; off, on and alarm. Additional event counters and elapsed time meters can be used to record the number of times and total duration of the alarm conditions that occurred since the last visit to the system. Combining the functionality of the event counters and elapsed time meters is conceptually correct, however, advancing technology has allowed many of these functions to be performed by one electronic programmable timer. Programmable times give the designer and operator greater control over the system's various operational modes including alarm conditions. A designer or operator can use programmable timers to:

- Increase the dose amount during periods of high flow
- Hold the pump on until the high level has receded.
- Internally record the number of high water situations to allow operational adjustment if necessary.

The goal of performance based standards and documentation of a system's treatment success has resulted in the need for and development of devices that can automatically adjust a system's operation and/or record its performance and/or broadcast an operational problem.

The first commonly available devices for monitoring a simple onsite system's status beyond its hydraulic operation are the products available for measuring sludge and scum depths in a septic tank. As the depth of sludge increases the overall performance of the tank is expected to decrease due to reduced detention time and the possibility of direct discharge of solids.

The SEPTICwatch™ illustrated in Figure 28 installed in a septic tank uses ultrasonic transducers and embedded microprocessor to continuously sense the positions of the floating solids, bottom solids and the liquid level within a septic tank. This data is sent back digitally to a control unit which can be programmed to alert the owner or operator when it is time to pump the tank.

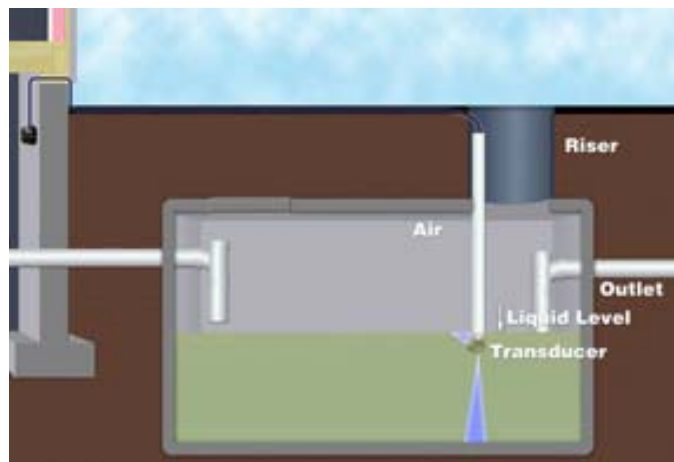

Figure 28: SEPTICwatch™

Electrical probes that can measure, conductivity, pH, temperature and D.O. are now available. The measurement of nitrogen compounds with a selective probe in the effluent is within reach but is expensive and requires frequent calibration and maintenance. Ideally, we will also soon see the development of devices that can monitor:

- Effluent BOD
- Effluent SS
- Effluent Fecal Coliform

It is expected that at least for the foreseeable future the direct measurement of system performance parameters will be left to systematic monitoring programs rather than by automated control devices.

4. Control Panels for System Management

With the growing concern about overall management of distributed decentralized systems control panels are being designed to interface with various communications networks (phones, internet, and microwave) for uploading or downloading information about system performance or operation. Panels are available which will dial out over either a dedicated or non-dedicated phone line to send alert messages to management entities. The information from the panel may be sent as simple signals to alert an operator's message beeper or as information that is uploaded to a web site. Panels are available which will interface with a variety of hand held data devices ranging from simple Palm type PDAs to uniquely designed and dedicated portable data acquisition and programming devices.

5. Common Internal Components of Panels

As panels become more complicated including features which operate the system on a day-to-day basis, provide alarms, record management data and interface with comprehensive management systems their components become more sophisticated. The following material is indented to give a brief introduction to some of the more common components of control panels.

a. Relays

Relays are common electrical devices that use a voltage and current to switch a large voltage and current. In a modern control device there can be several levels of switching between the float switch and the pump. Among these can be:

- A transistor switch that is at the output end of a computer controller. The transistor switch carries very small voltages and currents but enough to activate a low voltage relay.
- Low voltage relays may receive a voltage "signal" from either a transistor or possibly directly from a low voltage sensor of some sort.
- Medium voltage relays may control normal line voltage after receiving a signal from a low voltage relay.
- Motor control relays are usually larger mechanical relays that have big enough contacts to carry the large start up currents of the pump motor.

Figure 29 shows a portion of the inside of a control panel and illustrates the complex nature of the inside of a modern control circuit. This circuit board has several voltage relays, medium voltage relays and partly showing on the right of the photograph is the motor controller relay. In addition there are several override switches and indicator lights.

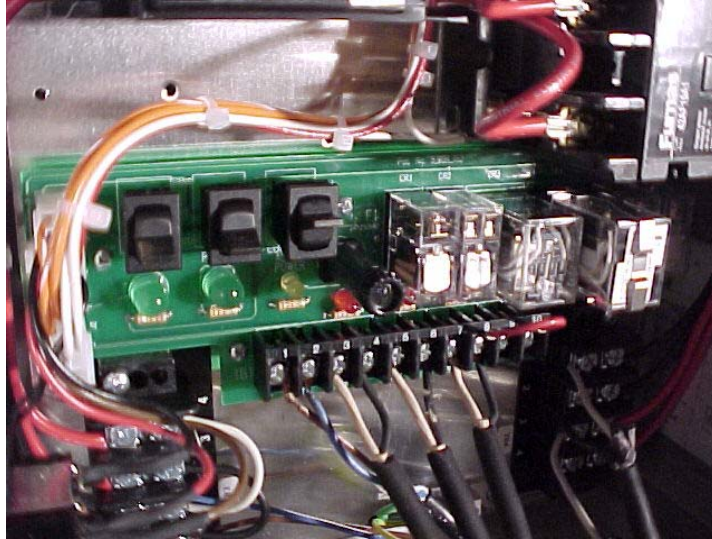

Figure 29: A Portion of a Control Panel

b. Programmable timer scheduler

The modern electronics industry provides the onsite designer and the company that support the designer with control panels a variety of mechanical, electronic and digital timers and schedulers to control an onsite system. Figure 30 and Figure 31 illustrate two of the several types of programmable timers that are common in onsite equipment today.

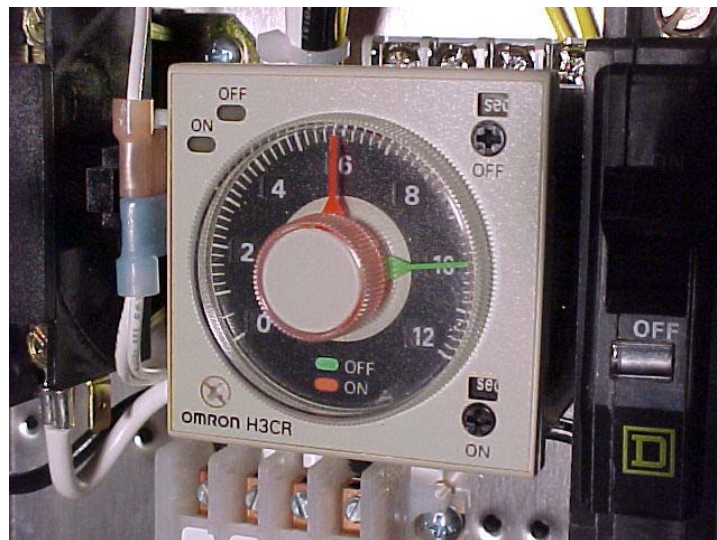

Figure 30: Analogue Programmable Timer



Figure 31: Digital Programmable Timer

IV. Design Considerations for Control Devices

A. Safety

Above all the safety to people who may come in contact with the modern mechanized and automated onsite wastewater systems need to be protected from harm. Control devices and the electrical components that they control can pose significant safety threats to all who come in contact with them either incidentally or as a professional. In addition to good design, safe and reliable equipment and competent installation and maintenance there are basic standards which all who design, install or work with the electrical components of onsite systems should adhere to. These include:

- Underwriters Laboratory Listing (U/L) that provides third party oversight of electrical electronic equipment safety, consumer assurance of superior product quality, and adherence to strict safety standards.

- National Electrical Manufacturers Association (NEMA) that provides a nationally recognized standard for the manufacture and performance of electrical components and product applications.
- National Electric Code (NEC) provides another nationally recognized standard for the safe and proper installation of electrical equipment as well as local inspection ability and representation.

The chart (Figure 32) on the following page defines the various NEMA ratings for the enclosures for control equipment.

NEMA Type 1 General Purpose	To prevent accidental contact with enclosed apparatus. Suitable for application indoors where not exposed to unusual service conditions.
NEMA Type 2 Drip tight	To prevent accidental contact , and in addition, to exclude falling moisture or dirt.
NEMA Type 3 Weatherproof	Protection against specified weather hazards. Suitable for use outdoors.
NEMA Type 3R Rain tight	Protects against entrance of water from a beating rain. Suitable for general outdoor application not requiring sleet proof.
NEMA Type 4 Watertight	Designed to exclude water applied in form of hose stream. To protect against stream of water during cleaning operations, etc.
NEMA Type 4X Corrosion Resistant	Designed to exclude water supplied in form of hose stream and used in areas where serious corrosion problem exists.
NEMA Type 5 Dust Tight	Constructed so that dust will not enter enclosed case. Being replaced in some equipment by NEMA 12 Types.
NEMA Type 6 Submersible	Intended to permit enclosed apparatus to be operated successfully when submerged in water under specified pressure and time.
NEMA Type 7 Hazardous Locations	Designed to meet application requirements of National Electrical Code for Class I, Hazardous Locations (Explosive atmospheres) Circuit interruption occurs in air.
NEMA Type 8 Hazardous Locations A.B.C. or D Class I – Air Break	Identical to Type 7, except the apparatus is immersed in oil.
NEMA Type 9 Hazardous Locations E, F, or G Class II	Designed to meet application requirements of National Electrical Code for Class II Hazardous Locations (combustible dusts, etc.)
NEMA Type 10 Bureau of Mines Permissible	Meets requirements of U.S. Bureau of Mines. Suitable for use in coal mines.
NEMA Type 11 Acid & Fume Resistant Oil Immersed	Provides oil immersion of apparatus such that it is suitable for application where equipment is subject to acid or other corrosive fumes.
NEMA Type 12 Industrial Use	For use in those industries where it is desired to exclude dust, lint, fibers & flyings, or oil coolant seepage.

Figure 32: NEMA ratings

Among the considerations that the control system designer must keep in mind in designing the electrical supply and control systems for an onsite system are:

- Proper grounding for the entire electrical system including the pumps and panel box.
- Appropriate wire gage for the power runs from the electrical supply panel to the control panel box and from the control panel box to the pumps and float switches
- Appropriate fuses and circuit breakers at both the control panel and at the electrical supply panel box.

B. Documentation

System documentation is essential for the continued safe and effective operation of the onsite system including its electrical and control equipment. This documentation should include:

- Operations and Maintenance (O&M) for the entire system including the electrical and control components. This should be provided by the equipment manufacturer through the designer or installer.
- The documentation should specifically include a system schematic that will communicate to the trained control specialist and/or electrician how the system is interconnected electrically.

Figure 3333 illustrates a system schematic for a simple alarm panel box similar to the alarm system shown. The alarm contacts represent the point where the float switch cable is connected to the alarm circuit. As can be seen this circuit has relatively few parts. Even so, a relay is needed to enable the alarm light to stay on after the single switch is set to the silence position.

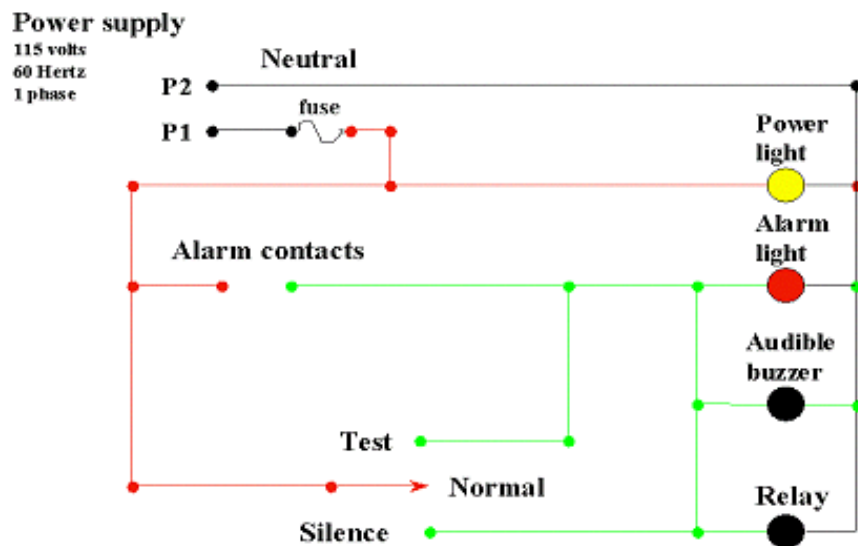

Figure 33: Simplex Alarm Circuit

As systems become functionally more complex there is a corresponding increase in the complexity of the control panel. Figure 74 illustrates a 4-float system controlling two pumps (duplex).

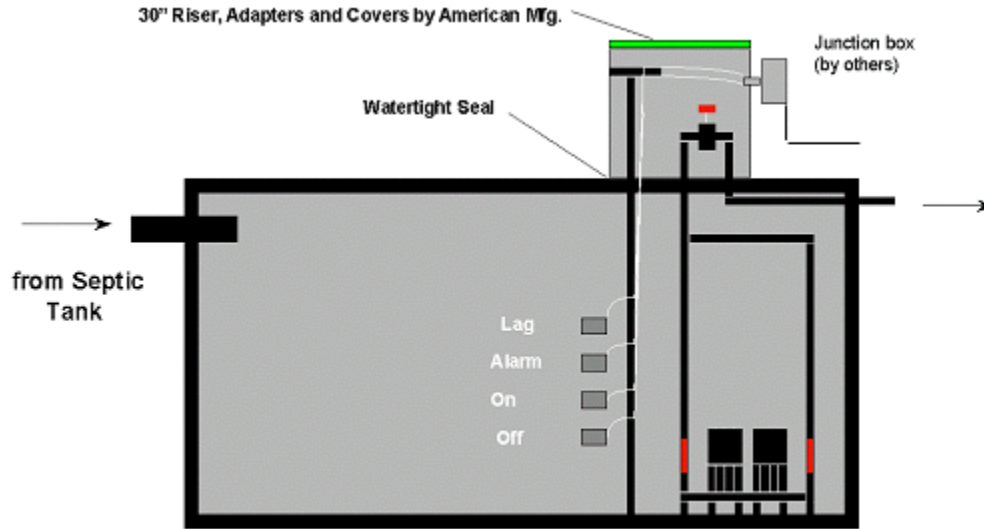

Figure 74: Duplex 4 float control system as it would be installed in a pump tank.

Figure 35 illustrates the correspondingly more complex system schematic for this four float, two-pump system. This circuit has motor control relays (C1, C2), an alternating relay (Alt) which will shift the pump power back and forth between the two pumps.

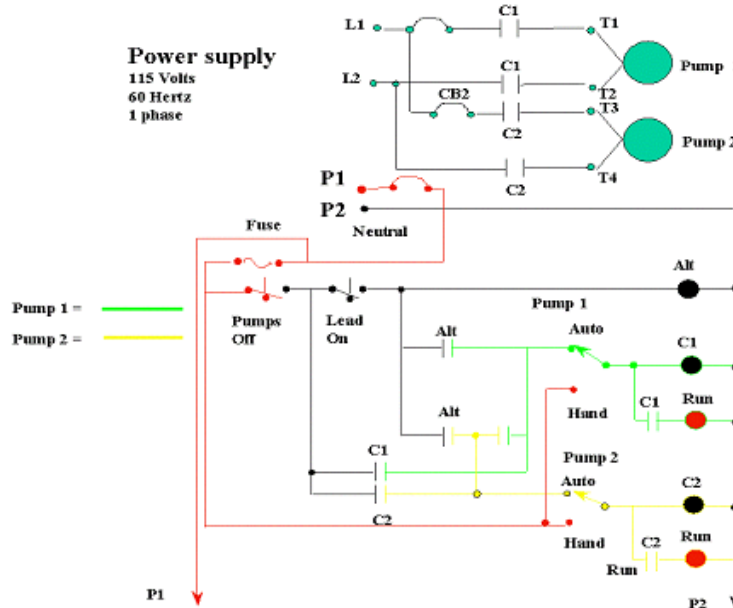

Figure 35: Duplex Pump Control Circuit

C. Regulatory Requirements

In addition to safety requirements and the need to document system performance there may be additional regulatory requirements that need to be addressed with the design of the control panel. Some additional regulatory features that come to mind include:

- Internal/Electronic records of changes of operational settings.
- Excessive discharge data.
- Regulatory monitoring of special site conditions including sensors for seasonal high groundwater or high flows on nearby sensitive watercourses.
- others as can be imagined

D. Owner Preferences

And finally but not less important the design of the control system for an onsite system should consider the preferences of the owner. After spending considerable sums of money on the site evaluation, design, installation and operation of the onsite system the owner will, hopefully, have gained greater insight into the importance of this environmental system. The owner may want control over additional features of the system that would not otherwise be required. Some additional features that come to mind include:

- Electrical Consumption
- Soil Moisture at the disposal field.
- Vacation settings
- Tampering alarms
- And others as can be imagined.

References

U.S. Environmental Protection Agency (USEPA), Onsite Wastewater Treatment Systems Manual, EPA/625/R-00-008, US Environmental Protection Agency, Office of Water, Washington D.C., 2002.

Hicks, T.G. Coordinating Editor, Standard Handbook of Engineering Calculations, 3rd Edition, McGraw-Hill, New York NY, 1995

Lindeburg, M.R., Engineering-In-Training Reference Manual, 8th Edition, Professional Publications, Inc, Belmont CA, 1992

Simon, A.L., Hydraulics, 3rd Edition, John Wiley & Sons, Inc., New York NY, 1986

Simon, A.L., Practical Hydraulics, John Wiley & Sons, Inc., New York NY, 1976