

# **University Curriculum Development for Decentralized Wastewater Management**

## **Hydraulics III: Pumps Module Text**

**Paul Trotta, P.E., Ph.D.  
Justin Ramsey, P.E.  
Chad Cooper**

**September 2004**

## **NDWRCDP Disclaimer**

This work was supported by the National Decentralized Water Resources Capacity Development Project (NDWRCDP) with funding provided by the U.S. Environmental Protection Agency through a Cooperative Agreement (EPA No. CR827881-01-0) with Washington University in St. Louis. These materials have not been reviewed by the U.S. Environmental Protection Agency. These materials have been reviewed by representatives of the NDWRCDP. The contents of these materials do not necessarily reflect the views and policies of the NDWRCDP, Washington University, or the U.S. Environmental Protection Agency, nor does the mention of trade names or commercial products constitute their endorsement or recommendation for use.

## **CIDWT/University Disclaimer**

These materials are the collective effort of individuals from academic, regulatory, and private sectors of the onsite/decentralized wastewater industry. These materials have been peer-reviewed and represent the current state of knowledge/science in this field. They were developed through a series of writing and review meetings with the goal of formulating a consensus on the materials presented. These materials do not necessarily reflect the views and policies of University of Arkansas, and/or the Consortium of Institutes for Decentralized Wastewater Treatment (CIDWT). The mention of trade names or commercial products does not constitute an endorsement or recommendation for use from these individuals or entities, nor does it constitute criticism for similar ones not mentioned.

## **Citation of Materials**

Trotta, P.D., and J.O. Ramsey. 2005. Hydraulics III: Pumps Text. *in* (M.A. Gross and N.E. Deal, eds.) University Curriculum Development for Decentralized Wastewater Management. National Decentralized Water Resources Capacity Development Project. University of Arkansas, Fayetteville, AR.

## I. Pumps

### A. The Use of Pumps in Onsite Systems

Pumps have many applications in Onsite Systems. Among the various uses for pumps in Onsite Systems are:

- Grinder pumps to pump raw sewage to a treatment device.
- Pumps to re-circulate partially treated effluent.
- Discharge pumps to transmit effluent to a dispersal field
- Effluent pumps to transmit effluent to a pressure or gravity sewer.
- Pumps to circulate fluid within a treatment device.

### B. Classification of Pumps

Among the many types of pumps available are:

- Special-Effect Pumps
- Jet
- Gas Lift
- Hydraulic Ram
- Electromagnetic
- Positive Displacement Pumps
- Rotary
- Gear
- Force
- Grinder

Several of these types of pumps have applications in onsite wastewater treatment and disposal. Other types may have applications that make them suitable for special purposes within the onsite environment.

In general, pumps can be divided into two major categories: dynamic or kinetic and positive displacement. Dynamic pumps continuously add energy to increase the fluid velocities. Displacement pumps periodically add energy to the water forcing an increase in pressure. Displacement pumps are divided into reciprocating and rotary types depending on the nature of the movement of the pressure-producing member.

Dynamic pumps can further be subdivided into centrifugal and special-effect pumps.

#### *1. Centrifugal Pumps*

Centrifugal pumps are the most widely used type of pump in the water and wastewater industry and are, therefore, discussed in greater detail than the other types. Centrifugal pumps depend on centrifugal forces for their operation. The centrifugal pump consists of a rotating impeller sealed in housing. The impeller is connected to a drive unit that

supplies energy to spin the impeller. As the impeller spins an area of low pressure is created in the center of the impeller. This low pressure allows water to be forced into the housing from atmospheric pressure on the water in the supply tank.

At the entrance to the pump housing, vanes or impellers rotate and draw liquid into the pump through a central inlet. After the water enters the housing, the spinning action of the impeller transfers energy to the water as velocity head or kinetic energy. The centrifugal forces are generated by the rotating impellers force the water or solids away from the center and force it out of the housing through the discharge opening at the outside edge of the housing. The water then travels out of the pump through the pump discharge. This process continues as long as the impeller continues to rotate and a supply of water is available.

The advantages of the centrifugal pump are its simple construction and operation, space requirements and constant rotary action.

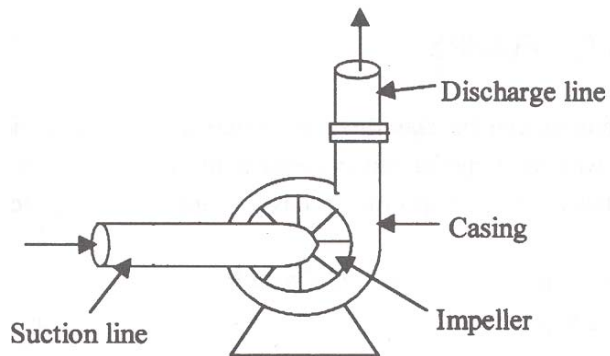
The centrifugal pump consists of a single rotating element inside a simple one-piece casing that can be made from a variety of materials to fit a variety of needs. The construction does not require all moving parts to be constructed to close tolerances, therefore, the amount of wearing on the moving parts is reduced and the operating life is extended. Through the design of the impeller and housing, the centrifugal pump can be made to pass solids due to the relatively large clearance between the impeller and the housing.

The amount of space required for the centrifugal pump is much less than other types of pumps in part because of having fewer moving parts. Fewer parts enhance its reliability and reduce maintenance requirements.

The centrifugal pump also has some disadvantages. The pump is not a self-priming pump. This is not a disadvantage if the pump can be placed directly into the wet well. If, however, the pump is placed in a dry well, a priming pump must be placed ahead of the centrifugal pump. The pump's efficiency is directly related to the head capacity of the pump. The highest performance efficiency is available for only a very small section of head-capacity curve.

The most crucial part of the centrifugal pump is the impeller. The size, shape and speed determine the pumps capacity. Figure 1 illustrates the components of the pump that are visible from the outside. Figure 2 illustrates the various impeller designs that can be used within a centrifugal pump

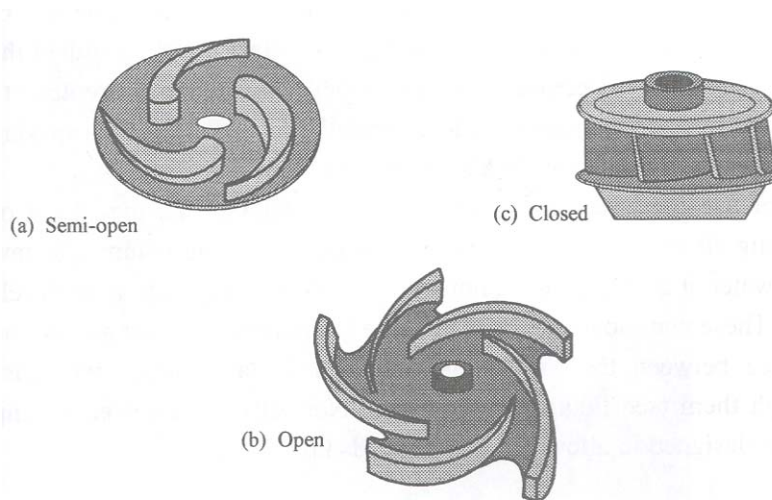
**Figure 1 Centrifugal Pump Exterior**



There are three types of impeller designs:

- Closed impeller
- Open impeller
- Semi-open impeller

**Figure 2 Impeller Designs**



The closed impeller uses a front and back shroud to leave only the suction eye and outer edge of the impeller open. The closed impeller is generally used for pumping clean water or water with minimum solids such as treated wastewater and can generate very high pressures.

Open impellers use curved blades or vanes that extend from the hub to the edge of the shroud. Open impellers are used to pump water with large solids or with high concentrations of solids. They are capable to pump high volumes of water at low pressures.

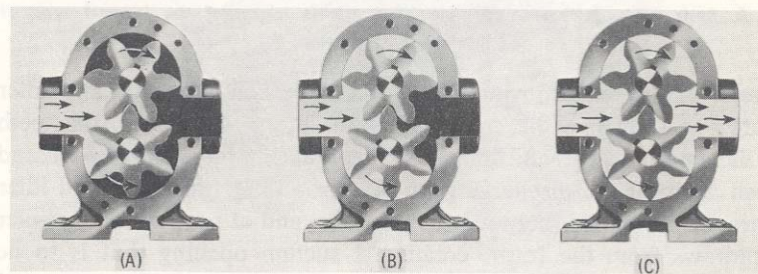
Semi-open impellers have only a shroud on the back of the impeller that covers the hub and extends to the edge of the vanes. Semi-open impellers are used for pumping liquids with medium-sized solids but are capable of handling high concentrations of solids. They are capable to pump high volumes of liquid at low pressures.

## 2. Rotary Pumps

The rotary pump continuously scoops water from the pump chamber. There are three classifications of a rotary pump: gear-type, vane-type and screw-type.

The gear-type pump shown in Figure 3 has two or more intermeshing gears or lobed members enclosed in a suitably shaped housing. The fluid is carried around the periphery of the gears and is forced through an outlet port.

**Figure 3 Gear-Type Hydraulic Pump**



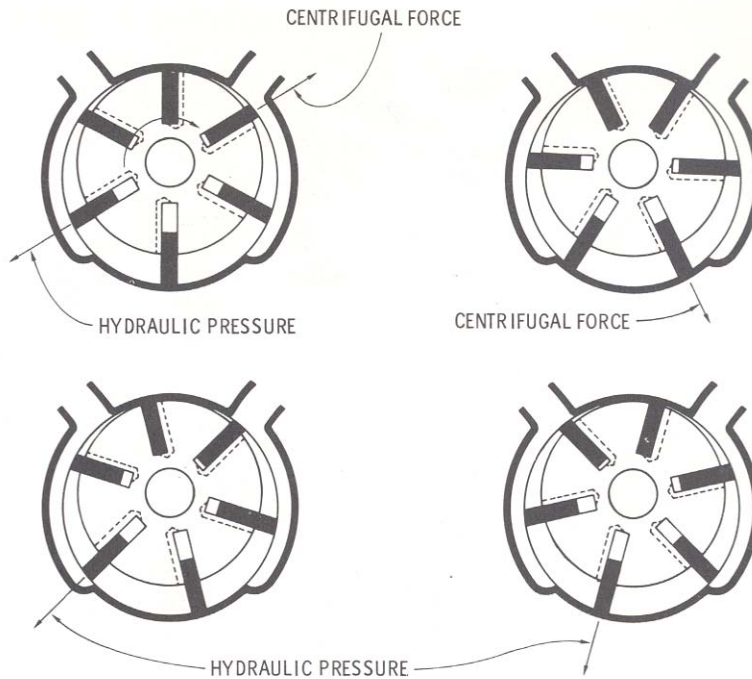
Courtesy Roper Pump Company

Fig. 2. Movement of a liquid through a gear-type hydraulic pumps: (A) Liquid entering the pump; (B) Liquid being carried between the teeth of the gears; and (C) Liquid being forced into the discharge line.

### a. Rotary Vane Type Pump

In a rotary vane type pump, the operation is based on the principle of increasing the size of the cavity to form a vacuum and then forcing the fluid out under pressure by reducing the size of the cavity. Instead of a piston entering the cavity, the water is forced into a smaller and smaller cavity increasing the pressure.

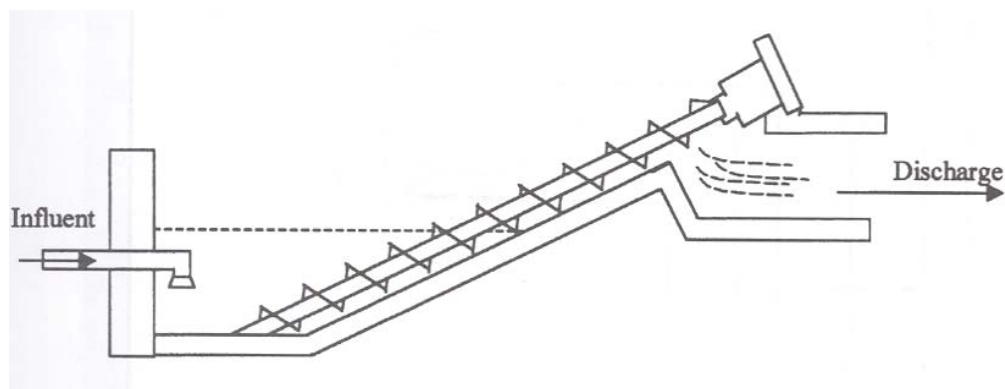
**Figure 4 Rotary Vane Pump**



**b. Screw-Type Pump**

In the screw-type pump, the liquid is carried between screw threads on one or more rotors and is displaced as the screws rotate and mesh. The advantages of a screw pump are they work well with a wide range of flows, pressures, and viscosities. They are self-priming and are tolerant of entrained air and other gasses.

**Figure 5 Screw Pump**

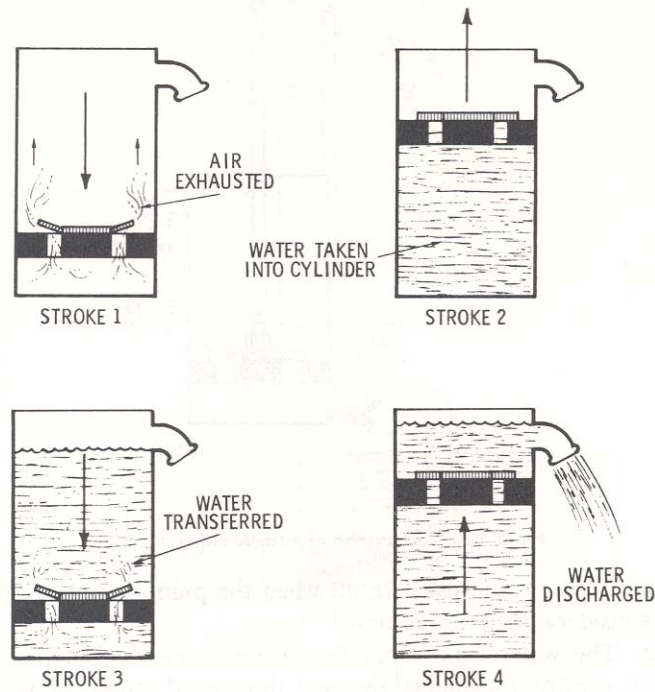


**3. Reciprocating**

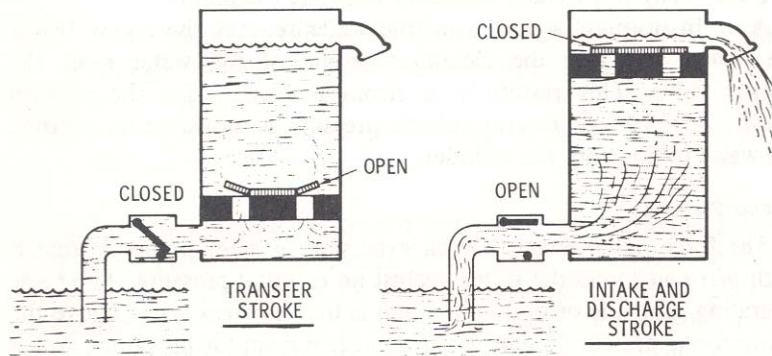
A piston or plunger differentiates the reciprocating pump from a centrifugal pump. There are two types of reciprocating pumps: lift pump and force pump.

A primed lift pump lifts water rather than adding pressure and forcing the water to move. A piston is located in a cylinder that is connected to a water source as the piston moves up the vacuum caused water to enter the cylinder (a flapper valve is typically used to not allow water to be forced back from where it came from). As the piston moves down, the water is forced through a bucket valve built into the piston itself. On the next upward cycle up the piston, the water is lifted and again water is drawn into the cylinder. Figure 6 shows the process of filling the cylinder, transferring the water, discharging the water and the operation of the check valve.

**Figure 6 Lift Pump**



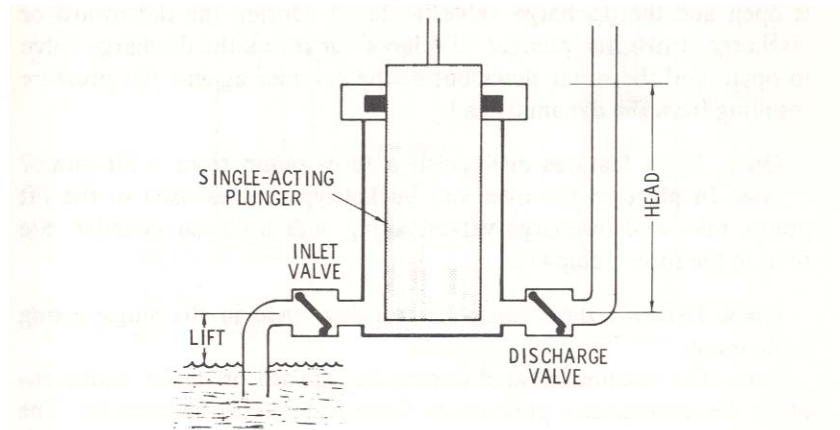
**Fig. 4. Four-stroke starting cycle for a single-acting lift pump.**



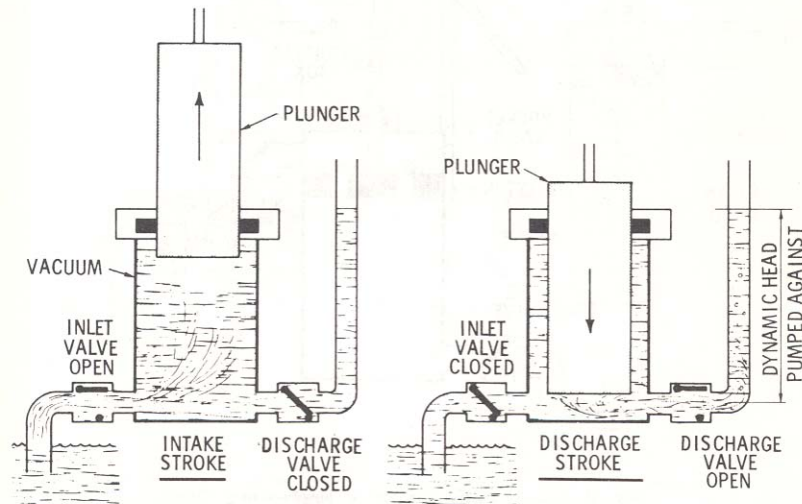
The force pump is another type of reciprocating pump. It actually lifts and forces the water against an external pressure. In a force pump, water is drawn into a cylinder in the

same way it is in a lift pump. The difference in the two is that on the downward stroke the water is forced through a discharge valve due to the pressure exerted on the water by the downward motion of the piston and the resulting decrease in volume in the cylinder as shown in Figure 7.

**Figure 7 Lift (Force) Pump**

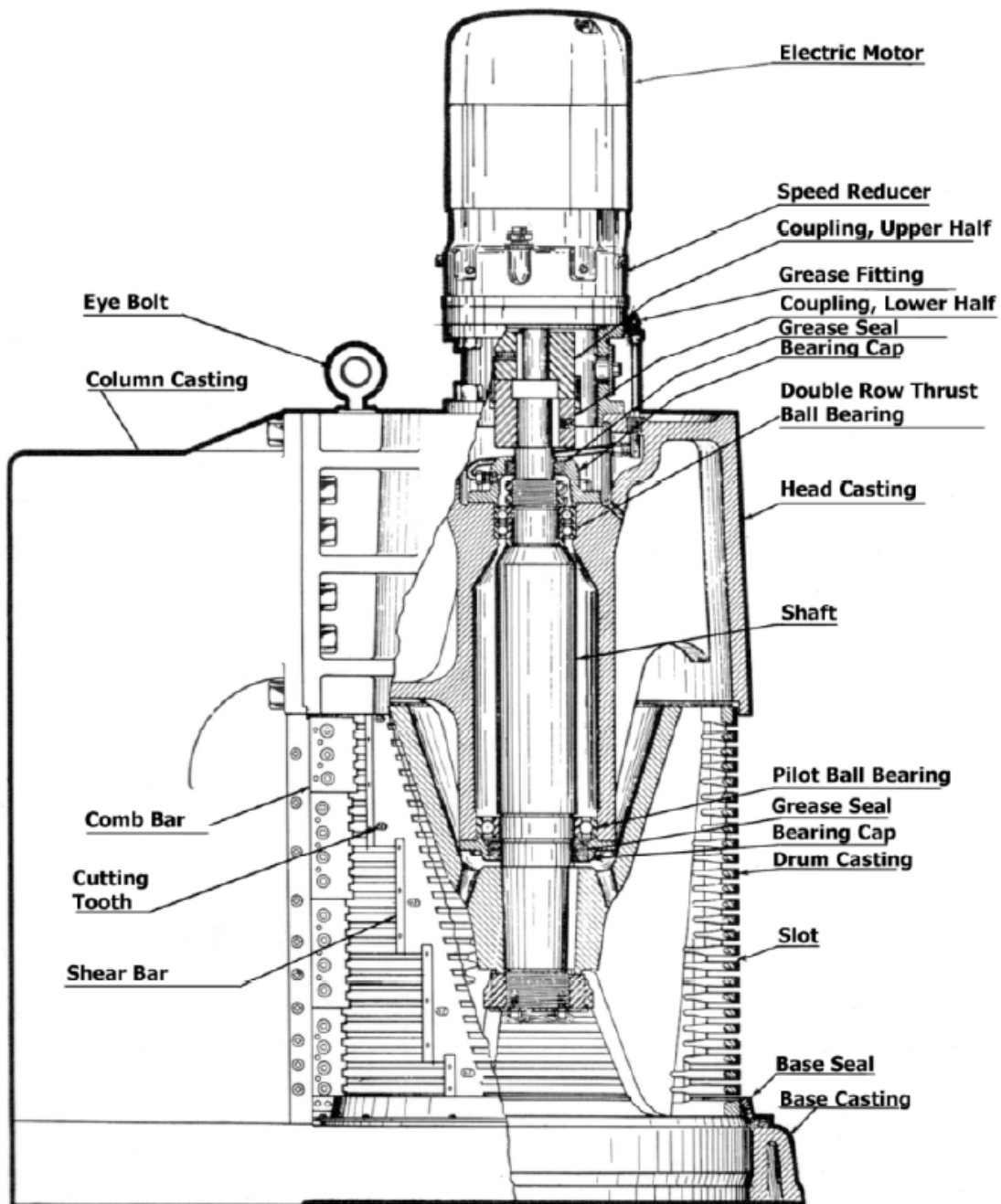


**Fig. 6. Basic construction of a single-acting plunger-type force pump.**



#### 4. Grinder Pumps

A pump that deserves some mention is the grinder pump. A grinder pump is commonly used to move untreated sewage. A grinder pump, as the name implies, grinds up the solids in raw wastewater as the water and accompanying solids enter the pump housing.



## C. Pump Design Issues

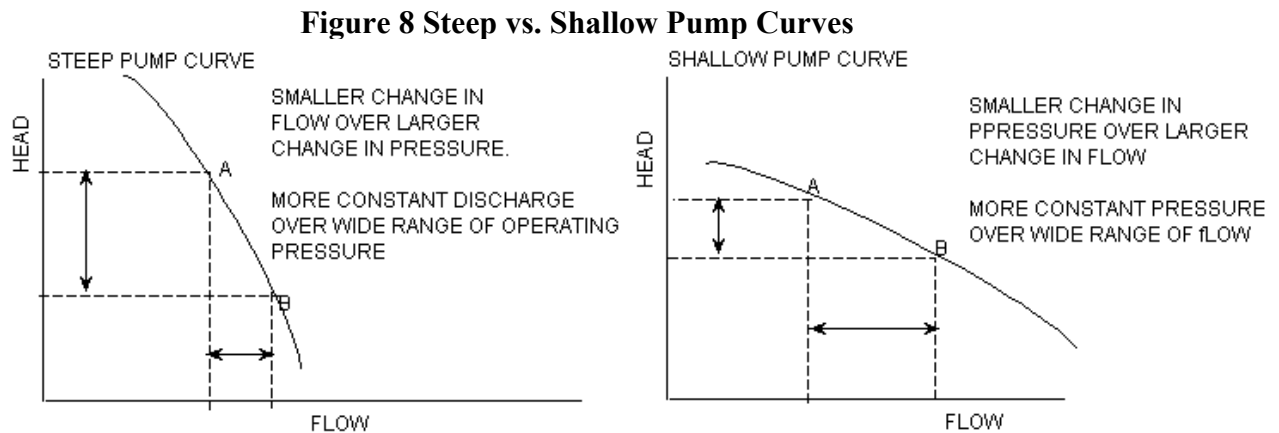
### 1. Efficiency

A pump must be driven by an engine or motor (often times referred to as the prime mover). The input power delivered by the motor to the pump is known as the brake pump power or brake horsepower. The net energy actually transferred to the fluid by the

pump is the hydraulic power. Due to frictional losses between the fluid and the pump as well as mechanical losses in the pump itself, the brake horsepower will be greater than the hydraulic power. The difference between the brake and hydraulic power is the friction power or friction horsepower and is accounted for by the pump efficiency.

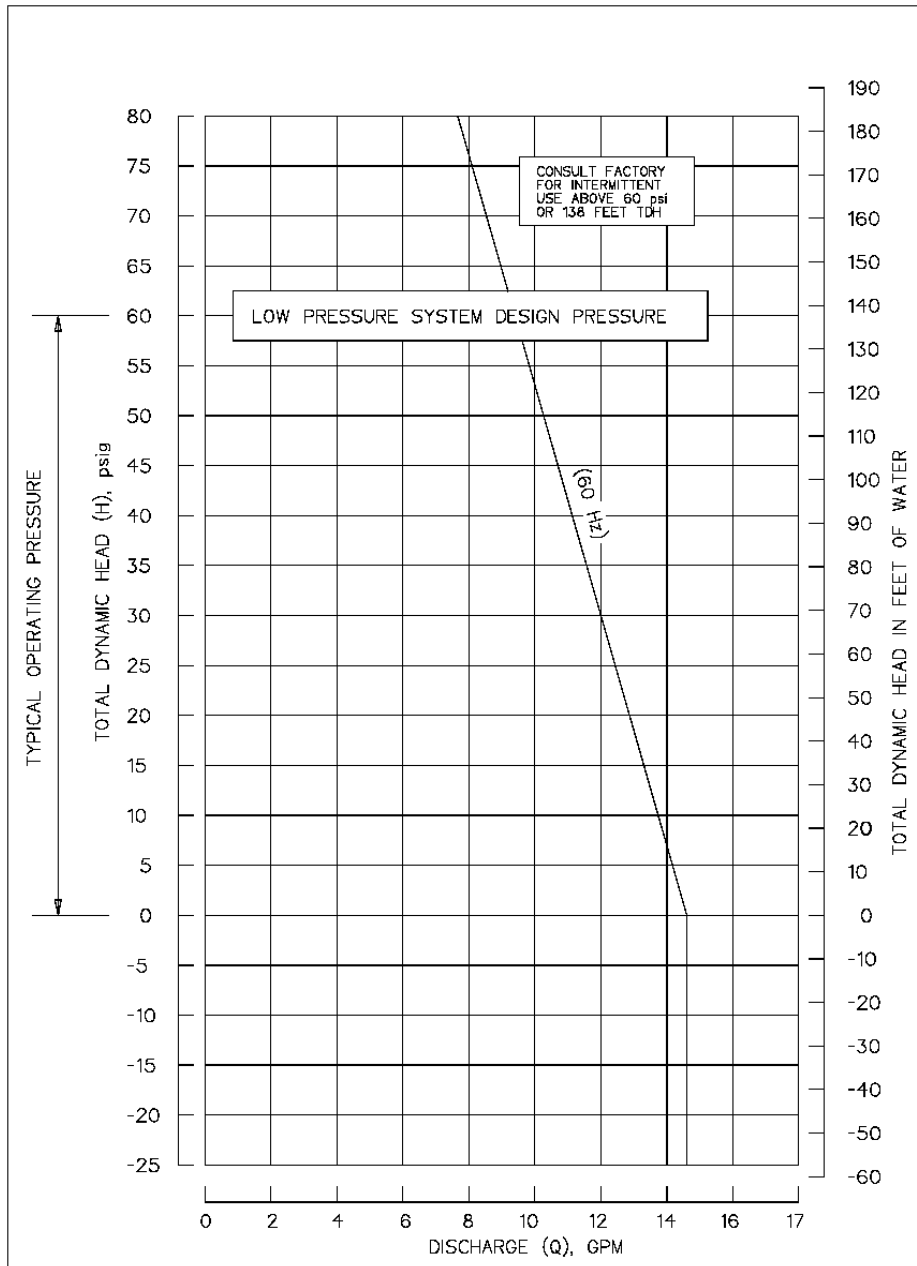
## 2. Steep versus Shallow Performance Characteristics

Pump curves may have a variety of characteristics. One important aspect of a pump's operating curve is the steepness of the curve. A pump with a steep pump curve will deliver a relatively stable discharge over a wide range of pressures. This can be important when a constant flow is required over a wide range of conditions at the inlet and outlet. On the other hand, significant changes in flow can occur over short periods in a home, business or factory. Corresponding changes in pressure can often cause problems. A pump with a shallow operating curve will deliver the same head over a wider range of flows.



Unpredictable variations in flows can pose difficult problems for low-pressure sewers because the increase in flows will cause an increase in head losses through the system. To overcome this potential problem, low-pressure sewers often use pumps with steep head curves as shown below in Figure 8. The pump described in Figure 8 will deliver between 8 and 14 gallons per minute with pressures ranging from 0 to 60 psi. A steep pump curve will provide a stable flow over various pressures.

**Figure 8 Steep Operating Curve**



Environment One-semi-positive displacement, progressing cavity pump curve.

### 3. Pump Horsepower

Work involves a force being exerted over a distance. Power is the rate of doing work or how much work is accomplished in a given period of time. One common unit for power is horsepower (hp) or kilowatts (kW). The standard for a horsepower was set at 550 foot-pounds of work in one second. (1 horsepower (hp) = 550 ft.lb/sec {0.746 kW}). When pushing water, two basic terms for horsepower are hydraulic horsepower (whp) and brake horsepower (bhp).

The whp is the flow of the water (which is a function of volume and time) times the height the water being lifted (height in feet can be converted to pressure) times the weight of the water. The water horsepower is the rate of work transferred to the water. The pumps bhp equals its hydraulic horsepower divided by the pumps efficiency. The horsepower is the rate of work transferred to the pump by whatever motor is turning the pump.

When a motor-pump combination is used, neither the pump nor the motor will be 100% efficient. Not all of the power supplied by the motor will be used to lift water because some of the power will be lost to friction as well as some of the power of the electric current driving the motor will be lost for a variety of reasons.

#### 4. *Affinity Laws*

Pump performance may be changed either by changing the impeller, speed or both. To change the pump performance characteristics, certain basic laws are valid for all centrifugal pumps. These laws are called the affinity laws.

Changing the impeller diameter (D) in the pump results in changes of flow (Q), head (H), and power (P) according to the following relationships:

$$\frac{Q_1}{Q_2} = \frac{D_1}{D_2}$$
$$\frac{H_1}{H_2} = \left(\frac{D_1}{D_2}\right)^2$$
$$\frac{P_1}{P_2} = \left(\frac{D_1}{D_2}\right)^3$$

When the motor speed or rpm (N) is changed on the pump, the following relationships occur:

$$\frac{Q_1}{Q_2} = \frac{N_1}{N_2}$$
$$\frac{H_1}{H_2} = \left(\frac{N_1}{N_2}\right)^2$$
$$\frac{P_1}{P_2} = \left(\frac{N_1}{N_2}\right)^3$$

The two groups of equations display that the change in impeller diameter has the same influence on the pump performance as the change in motor rpm.

## 5. Multiple Pumps

### a. Parallel

Parallel operation is achieved by having two pumps discharge into a common pipe. Parallel operation is used to increase flow. Pumps in parallel increase the flow, but the dead head remains the same as one pump is working. Simply stated using two pumps in parallel will double the flow only when the head remains the same. To see the net result of using two pumps in parallel, the system curve must be compared to the pump characteristic for the two pumps in parallel

Pumps in parallel can also enable one pump to be shut down during low demand. The pumps can be used individually or together.

### b. Series

Series pump operation is achieved by having one pump discharge into the suction inlet of the next. This arrangement is used primarily to increase the discharge head (when system head is too great to overcome with a single pump), some increase in flow capacity is also expected. Simply stated using two pumps in series will double the head only when the flow remains the same. To see the net result of using two pumps in series, the system curve must be compared to the pump characteristic for the two pumps in series.

Figure 9 illustrates the effect of two pumps in series or two pumps in parallel when installed in a specific system. In both cases, an increase in head and discharge will result but the ratios of the increase in head and flow will depend upon the system curve and the pump curves taken together. It can not be assumed that two pumps in parallel will always deliver twice the flow or twice the pressure.

**Figure 8** Pumps in Parallel and Series in a System

